

AS-i Bus System



Series 79 Pneumatic Actuator

A group of European Automation Companies had a vision for a simple, cost effective networking system. These companies worked together for a common goal, and in 1993 the AS-i (Actuator Sensor Interface) Network was formed.

AS-i (Actuator-Sensor Interface) offers many of the benefits of more complex and costly bus systems, but does it at a substantially lower cost and with greater simplicity. The Actuator-Sensor Interface is ideally suited for controlling valves, actuators and many other field devices in your processing application.

This interface can be used for stand-alone process control, or it can be used together with a higher-level bus control system. AS-interface does not compete with higher-level bus systems; it should be seen as a complimentary system that offers low cost, reliable device control for binary and analog devices.

Reliability, simplicity and interoperability make AS-interface a cost effective connection/control solution, particularly where low installation costs is imperative.



Series 92 Electric Actuator

A single pair of wires, which handles power and communications, is used to control the network by means of “chaining” the actuators with the PLC. Each actuator (or device) will then have its own unique address within the system and only that device with the proper address will respond to system commands.

AS-i is best known for its yellow flat cable, which is pierced by insulation displacement connectors so that the expense of tees and complex connectors is avoided. Devices are simply clamped onto the cable.

Digital signals are encoded on this cable in a sinusoidal signal, which has a very narrow frequency bandwidth. Filtering which is distributed through the network rejects all extraneous frequencies, and in this way AS-i can be operated in electrically noisy environments without experiencing transmission errors.

The yellow flat cable carries low current (30 VDC) for input devices such as solenoids, relays, etc. as well as the AS-i signal. If power for outputs (such as electric actuators) is required, an additional BLACK flat cable is available.



**Series 79 Pneumatic Actuator
and Ball Valve**



**Series 79 Pneumatic Actuator
and Butterfly Valve**

Standard Features

- Low profile, compact package for ease in mounting where space limitations are an issue.
- Actuators and accessories meet ISO and NAMUR Standards, therefore no special training is required for field installation/conversion.
- M12 SS connection utilized for network interfacing - NEMA 4X rated.
- No moving parts with proximity sensor triggered by a target puck.
- Sealed proximity switch so open cavity condensation is not an issue.
- Each actuator has visual indication and proximity feedback to the PLC.
- Each component meets NEMA 4X.
- Low power consumption allows power and data communications via the same two-wire cable.
- A system of 31 valves requires less than 5 amps of AS-i power.
- Expandability with gateway and/or insulation displacement connector.
- 5 ms reaction time from PLC to cycling of unit.
- Conformance to AS-i Certificate ZU15101.

AS-i Bus System

Pneumatic Specifications

Mounting: ISO/NAMUR

Connection: M12 SS

AS-i Current Draw: .16 AMP

Electrical Design: 2-input/2-output

Voltage Range: 26.5-31.6 VDC

Sensor/relay supply: AS-i

Air Connection: 1/4" FNPT

Solenoid coil: Epoxy encapsulated

Solenoid protection: NEMA 4x

Reverse polarity protected

Sample Specification

All pneumatically actuated AS-interface systems shall have a 2-input/2-output proximity sensor and a solenoid directly mounted to a Series 79 Actuator. The sensor shall be constructed of Pocan® Thermoplastic Polyester, NEMA 4X protection, operation and function LED's, voltage range of 20-30 VDC, and a stainless steel M12 socket connection to the network. The solenoid shall have an anodized aluminum body with a 1/4" NPT air inlet, manual over-ride, and NEMA 4X protection. Spool/piston shall be synthetic resin with NBR and FKM O-rings, and fitted with an epoxy-encapsulated coil directly coupled to the proximity sensor, as supplied by Asahi/America Inc.



**Series 92 Electric Actuator
and Ball Valve**



**Series 92 Electric Actuator
and Butterfly Valve**

Standard Features

- AS-i components are installed inside standard actuator housing; actuator dimensions and protection remain unchanged.
- M12 SS connection utilized for network interfacing – NEMA 4X rated.
- No moving parts with proximity sensor triggered by cams.
- Each actuator has visual indication and proximity feedback to the PLC.
- Each component meets NEMA 4X.
- Low power consumption allows power and data communications via the same two-wire cable.
- A system of 31 valves requires less than 5 amps of AS-i power.
- Expandability with gateway and/or insulation displacement connector.
- 5 ms reaction time from PLC to cycling of unit.
- Conformance to AS-i Certificate ZU11601

AS-i Bus System

Electric Specifications

Mounting: Inside actuator housing

Connection: M12 SS *

AS-i Current Draw: .13 AMP

Electrical Design: 4-input/4-output

Operating Voltage: 26.5-31.6 VDC

Sensor/relay supply: AS-i

Relay outputs: 12VAC/VDC, 24VAC/VDC,
115 VAC, or 220 VAC

Actuator protection: NEMA 4x, [7 & 9]*

Reverse polarity protected

*Consult factory for specifications

Sample Specification

All electrically actuated AS-interface systems shall have a double proximity switch and a PCB card installed inside of the Series 92 Actuator without compromising the protection. The proximity switch shall have 2 independent spst contacts triggered by the standard actuator cams and enclosed in a Pocan® Thermoplastic Polyester housing NEMA 4X rated. The PCB card shall be short circuit protected, reverse polarity protected with 4 relay outputs. Relay outputs shall be rated 6Amps and accept 12VAC/VDC, 24VAC/VDC, 115 VAC, OR 220 VAC. The PCB card shall wire direct to an M12 connector for acceptance of AS-i power/signal, as supplied by ASAHI/America Inc.

AS-i Bus System

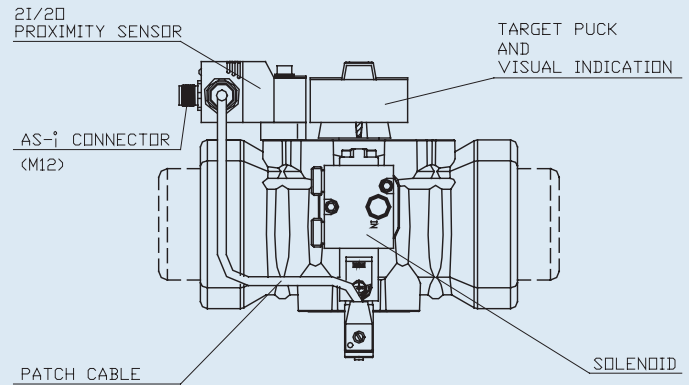
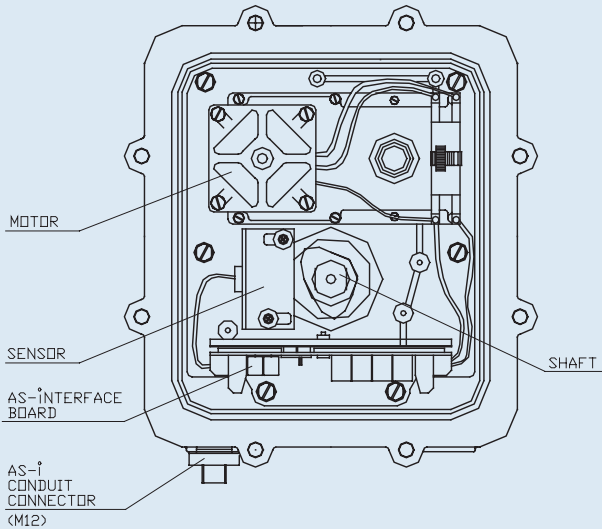
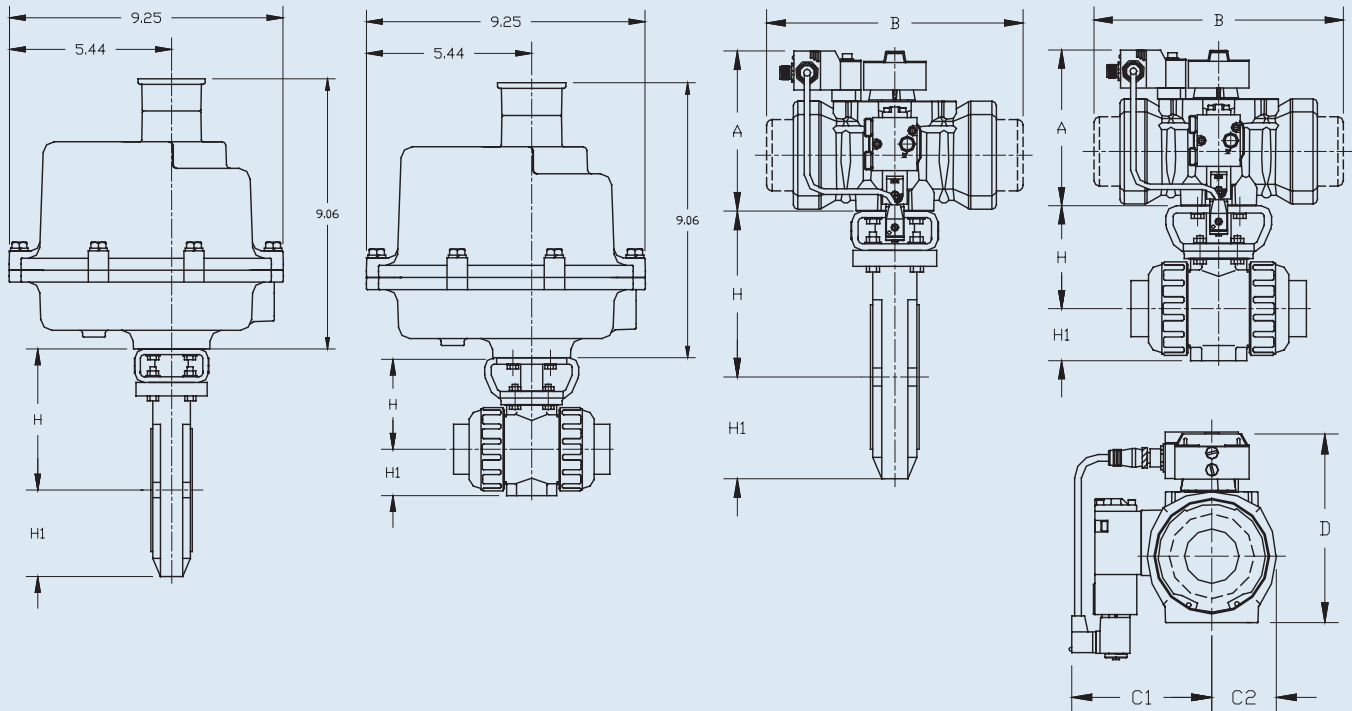

Dimensions (IN.)

Series	A	B	C1	D
AP79PN	4.36	4.22	3.52	3.91
AP79PSN	4.36	5.55	3.52	3.91
BP79PN	5.38	4.92	3.78	5.32
BP79PSN	5.38	6.22	3.78	5.32
CP79PN	5.62	7.01	4.22	5.56
CP79PSN	5.62	9.06	4.22	5.56
DP79PN	6.96	9.21	4.69	6.90
DP79PSN	6.96	12.13	4.69	6.90
E79PN	8.89	12.13	5.59	8.83
E79PSN	8.89	18.50	5.59	8.83
F79PN	11.47	15.98	6.18	11.70
F79PSN	11.47	25.43	6.18	11.70
G79PN	12.67	20.63	7.25	12.90
G79PSN	12.67	27.32	7.25	12.90

Dimensions (IN.)

NOMINAL SIZE	H Dim.		H1 Dim.	
	INCHES	mm	Type 21 Ball Valve	Type 57 Butterfly Valve
1/2	15	2.76	1.14	-
3/4	20	3.01	1.38	-
1	25	3.29	1.54	-
1 1/4	32	3.64	1.85	-
1 1/2	40	3.98	2.17	5.51
2	50	4.43	2.60	5.75
2 1/2	65	5.12	2.83	6.18
3	80	5.47	3.35	6.46
4	100	6.97	4.33	7.16
6	150	-	-	8.97
8	200	-	-	11.25