

K10

Intrinsically Safe Electro-Pneumatic Positioner Operating Manual

Pneumatic Connection

Single Acting Actuator (Spring Return):
For single acting actuators Outlet Port 2 is to be plugged. Outlet Port 1 is to be piped to the actuator inlet port that acts against the spring. (Increasing signal causes pressure to increase in Outlet Port 1 of the positioner).

Double Acting Actuator (Double Return):
For double acting actuators Outlet Port 2 is piped to drive the actuator towards the fail position. Outlet Port 1 is piped to drive the actuator away from the fail position. (Increasing signal causes pressure to increase in Outlet Port 1 of the positioner and pressure to decrease in Outlet Port 2 of the positioner).

Note: Air supply to the positioner must be clean, dry, oil free instrument air per ISA-S7.3. Maximum supply pressure is 120 psi. All pneumatic connections are 1/4" NPT.

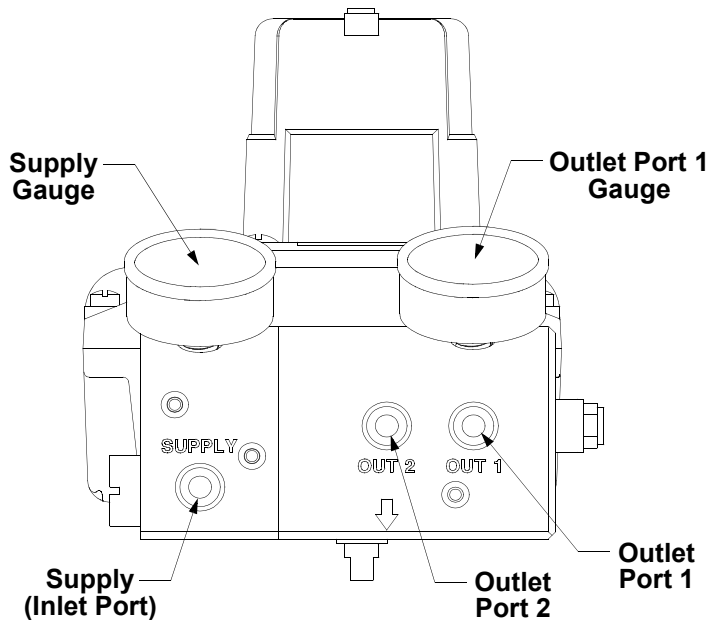

Electrical Connection

The electrical connection (4-20 mA Loop Input) to the K10 positioner is polarity sensitive. Connect the 4-20 mA Loop Input to terminal block J1 on the Connector Board as shown on the right (Positive lead to terminal point 3 and negative lead to terminal point 2). The wire size can range from 20 to 14 AWG. J1 is removable (plugs into a pin header soldered to the PCB) for ease of wiring and service.

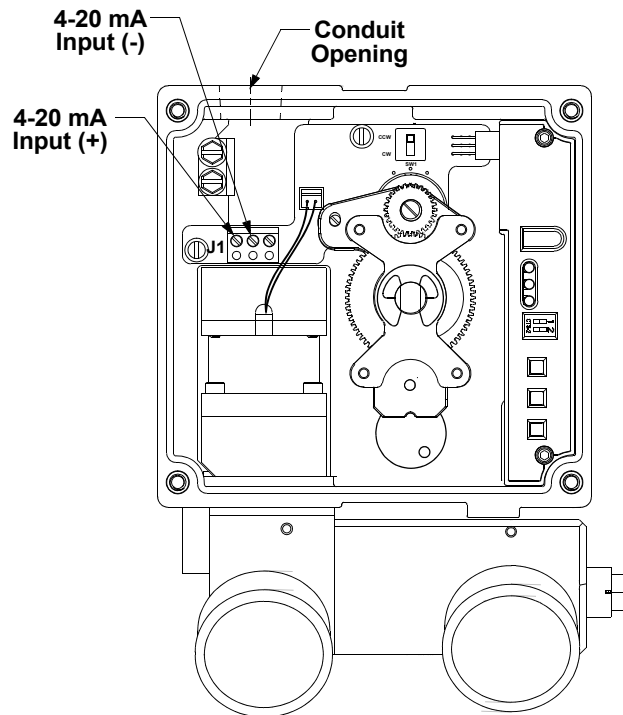

Position Sensor Initial Angle (Setting Mode)

The K10's Position Sensor, which measures the absolute position of the valve, has a limited operating angle for proper position measurement. The Position Sensor must remain within the operating angle in both the open and fail valve positions. This is accomplished by initially setting the Position Sensor angle while the valve is in the fail position. The K10 has a mode of operation to accomplish the setting of this initial angle using the following steps.

1. Apply loop current to the positioner and adjust to 12 mA.
2. Press & hold both the high and low buttons until the actuator is driven to span position. Release both buttons to remove air pressure from Outlet Port 1.
3. If the valve fails clockwise and strokes counter-clockwise, then set switch SW1 to the CCW position. If the valve fails counter-clockwise and strokes clockwise, then set switch SW1 to the CW position (see figure to right).
4. With no buttons pressed and the actuator in the fail position, push the Main Shaft Gear (larger of the two) down until it disengages from its shaft locking position.
5. Rotate the Main Shaft Gear (both gears will turn), until only the green LED is flashing.

Note: If the LED is already green, skip 5 and go to 6.

6. Pull up the Main Shaft Gear allowing it to re-engage on the shaft locking it into position.
7. Press and hold the High Calibration button until the valve fully strokes away from the fail position while watching the LED's. The red or yellow LED's must not light as long as the High Cal button is being held down. If the red or yellow LED lights while the High Cal button is being held down, then the Position Sensor Orientation and Actuator air piping are out of phase. Correct the phase error by changing the position of SW1 and repeat this procedure starting from step 2.
8. Release the High Calibration button and watch the red LED. The red LED will flash until the valve reaches the fail position.
9. Press the Low Calibration button to exit the Position Sensor Setting Mode (if no buttons are pushed then this mode will time out automatically in about 2 minutes).

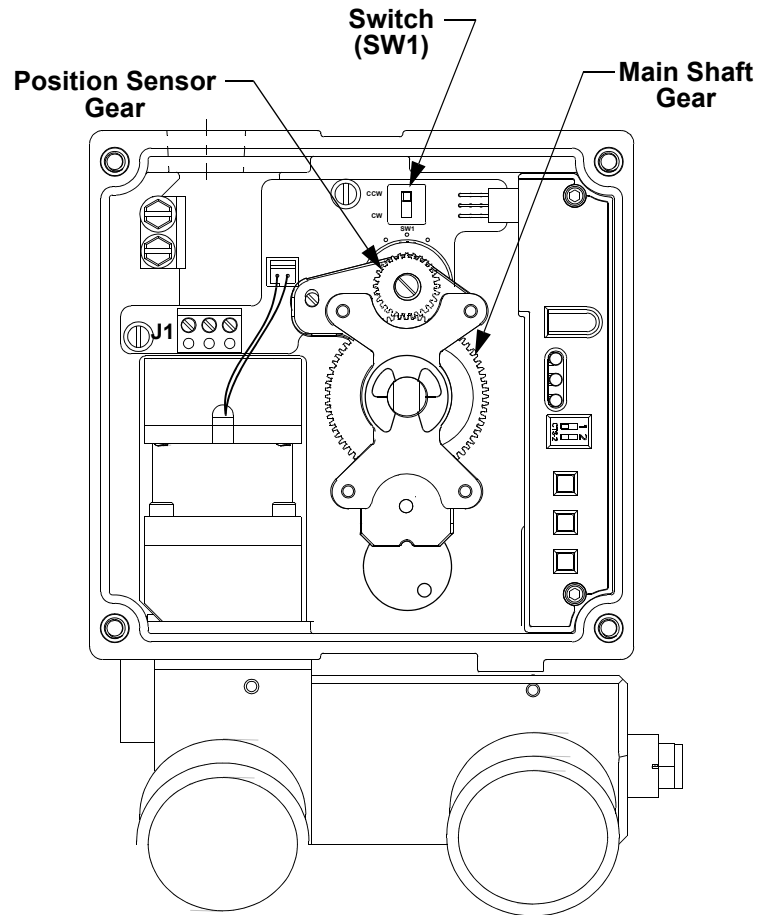

Calibrating The K10 Positioner

Once the K10 and actuator have been connected and the initial angle has been set. Low and High Calibration can be performed on the K10. Low Calibration refers to the input current value that drives the valve into the fail position. High Calibration refers to the input current value that drives the valve into the Span Position. Calibration adjusts parameters internal to the K10 that are specific to the actuator, and input current values. The parameters that are adjusted are, the Gain of the K10 servo loop. the end position (Zero/Span) of the valve travel, and Drop-Off point (input current level at which the transducer is forced to the extreme position, to insure that the valve is fully open or closed). The calibration routine uses the input current value to set it's internal adjustment, so it is important that the input current does not change during the calibration routine.

**** To Do a Low Calibration: (Zero Position)**

1. Set the Input Current level to the value that drives the valve into the fail position (typically 4 mA).
2. Start the Low Calibration routine by pressing and holding the **LOW CAL** button on the K10 until the Yellow LED flashes or by pressing the **LOW** button on the IR Remote (may require security code entry).
3. Observe the flashing Yellow LED on the K10 which denotes the various stages of the calibration routine:
 - a.) Flashing 1 time indicates **Zero** position set routine.
 - b.) Flashing 2 times indicates **Transducer Self Calibration** routine.
 - c.) Flashing 3 times indicates **Gain** setting routine.
4. When the Green LED begins to flash the Calibration is completed. If the Red LED flashes this is an indication that one of the Calibration routines could not be completed. The number of Red LED flashes indicates the calibration routine that failed.

**** To Do a High Calibration: (Span Position)**

1. Set the Input Current level to the value that drives the valve into the span position (typically 20 mA).
2. Start the High Calibration routine by pressing and holding the **HIGH CAL** button on the K10 until the Yellow LED flashes or by pressing the **HIGH** button on the IR Remote (may require security code entry).
3. Observe the flashing Yellow LED on the K10 which denotes the various stages of the calibration routine:
 - a.) Flashing 1 time indicates **Span** position set routine.
 - b.) Flashing 2 times indicates **Transducer Self Calibration** routine.
 - c.) Flashing 3 times indicates **Gain** setting routine.
4. When the Green LED begins to flash the Calibration is completed. If the Red LED flashes this is an indication that one of the Calibration routines could not be completed. The number of Red LED flashes indicates the calibration routine that failed.

Calibration Complete:

**** Note: For split range enter desired input values during low & high calibration.**

Advanced Functions

The K10 has the ability to change the calibration settings (Gain, Zero, Span, and Drop-Off) manually. This function was intended to make minor changes in the calibration values after doing the Low and High calibration. Some examples where this might be used are decreasing the Gain if the valve still shows some overshoot on rapid position changes, or increasing the High Drop-Off point so it will not be in effect at 20mA. ***Exercise caution if using the manual calibration, mis-adjustment of these settings on the K10 positioner can result in erratic behavior or failure of operation, and may require resetting the EEPROM before auto-calibration can be performed again.***

To Do a Manual Calibration Adjustment:

Before performing a Manual Calibration Adjustment the positioner needs to be calibrated as described previously.

1. Apply Input Current to the K10.
2. Start the Manual Calibration routine by pressing and holding the Function (center) button on the K10 until the Green and Yellow LED flashes.
3. Observe the flashing Green and Yellow LED on the K10 which denotes the various stages of the manual calibration routine, pressing the Function (center) button again advances to the next stage:
 - a.) Flashing 2 time indicates **Manual Gain** adjustment.
 - b.) Flashing 4 times indicates **Low Drop-Off** adjustment.
 - c.) Flashing 3 times indicates **Zero** position adjustment.
 - d.) Flashing 6 times indicates **High Drop-Off** adjustment.
 - e.) Flashing 5 times indicates **Span** position adjustment.
4. To alter any characteristics of the positioner follow the following steps:
 - a.) **Manual gain** Increase the positioner gain by pressing and holding the High Cal button. Decrease the Positioner gain by pressing and holding the Low Cal button. The maximum adjustment has been achieved when the red LED lights.
 - b.) **Low Drop-Off** Increase the mA input signal that the positioner drops output port 1 pressure by pressing the High Cal button. Decrease the mA input signal that the positioner drops output port 1 pressure by pressing the Low Cal button.

- c.) **Zero position** [To adjust the zero position to a point other than the hard stop of the valve the Low calibration of the positioner must have been performed at a current slightly lower than the zero position current. (Ex. If the zero position current is 4.0 mA the Low Calibration as described in the previous section needs to be performed at 3.9 mA.)] Increase the zero position by pressing and holding the High Cal button. Decrease the zero position by pressing and holding the Low Cal button. Continue to increase or decrease the zero position by repeatedly pressing and holding the buttons.
 - d.) **High Drop-off** Decrease the mA input signal that the positioner drops output port 2 pressure by pressing and holding the Low Cal button. Increase the mA Input signal that the positioner drops output port 2 pressure by pressing the High Cal button.
 - e.) **Span Position** [To adjust the span position to a point other than the hard stop of the valve the High calibration of the positioner must have been performed at a current slightly higher than the span position current. (Ex. If the span position current is 20.0 mA the High calibration as described in the previous section needs to be performed at 20.1 mA.)] Decrease the span position by pressing and holding the Low Cal button. Increase the span position by pressing the High Cal button.
5. The Input Current can be changed during the test to observe the adjustment effects on the K10 behavior.
 6. To save the adjustments and exit the Manual Calibration Mode the Function (center) button must be held for approximately 5 seconds (green and yellow flashing LED's will change to flash just green when adjustments are saved) This procedure to save and exit can be performed from any stage during the Manual Calibration.
 7. Pressing the Function (Center) button during the High Drop-Off adjustment exits the Manual Calibration Mode without saving any adjustments made.

The (IR) Remote Control With The Positioner

The positioner has the ability to be operated (calibrated) via an Infrared (IR) Remote Control. The positioner can be calibrated by using the buttons on the positioner module, however this requires the removal of the top cover. With the (IR) Remote Control the positioner can be calibrated without the removal of the top cover. If the 4-20 mA input current connected to the positioner is not available or the Position Sensor Initial Angle must be set then the removal of the top cover is required. Although the positioner is configured for use with the remote, the (IR) Remote Control is not provided with the positioner. The (IR) Remote Control is an option and must be purchased separately.

Programing The IR Remote Control

The IR Remote Control is programmed at the factory and should not need to be programed again, unless the batteries are removed for an extended period of time (greater than 10 minutes). To program the IR Remote press the “P1” button then press and hold the “P” button until the red LED blinks twice, then press “0”, “0”, “8”, “1” after which the red LED on the IR Remote blinks twice to confirm the entry. Press the “P2” button then press and hold the “P” button until the red LED blinks twice, then press “0”, “0”, “5”, “4” after which the red LED blinks twice to confirm the entry.

THE IR REMOTE CONTROL BUTTONS

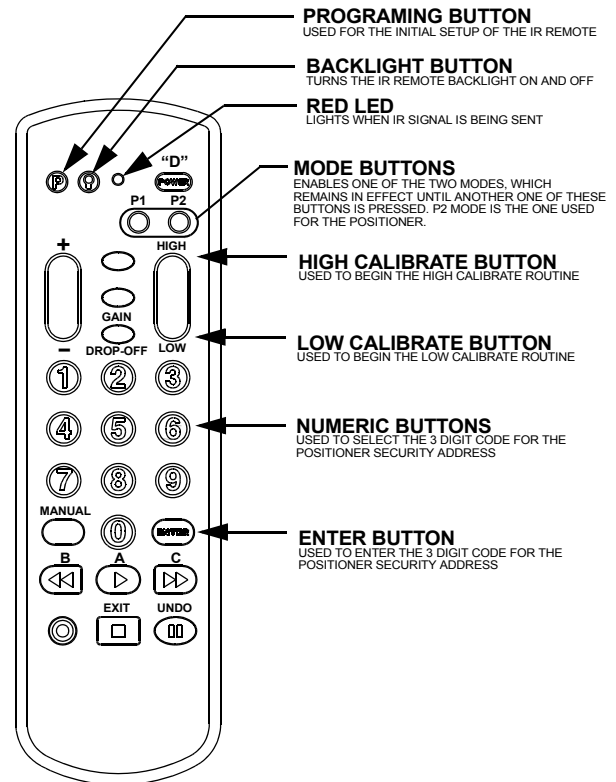

Using The IR Remote Control

The positioner has two operating modes when using the IR Remote.

In the first mode, the positioner will immediately act upon commands from the IR Remote (this can be used when the positioner being calibrated is the only one that will be within range of the IR Remote signal, such as one positioner in a closed room). This mode is enabled by setting the positioner DIP switch position 2 (the one closest to the Low Cal Button) to the “ON” position (away from the LED’s).

In the second mode, the positioner will not act upon commands from the IR Remote until a 3 digit security code is entered (this can be used when there are multiple positioner’s within range of the IR Remote signal). This mode is enabled by setting the positioner DIP switch position 2 (the one closest to the Low Cal button) to the “OFF” position (toward the LED’s). Once the correct code is entered (3 digits followed by the ENTER button) the positioner is enabled to act upon IR Remote commands for 5 minutes. The IR Command Enable time counts down to zero, or is set to zero (positioner no longer acts upon commands) when the positioner gets an ENTER from the IR Remote, that was not preceded by the correct 3 digit security code.

Setting The Positioner Security Code

The security code is initially set by entering a 3 digit code, while the positioner is in the “Position Sensor Initial Angle” setup mode. To set a security code enter “Position Sensor Initial Angle” setup mode, by pressing and holding the High and Low Calibration buttons on the positioner until the Yellow and Green LED’s flash. Press the 3 digits for the security code on the IR Remote then press the ENTER button on the IR Remote (entering the code too quickly may prevent the positioner from reading it correctly, pause at least 1/2 second between each button pressed and hold each button down for at least 1/2 second on the IR Remote). When the Low Calibration button on the positioner is pressed to exit the “Position Sensor Initial Angle” setup mode the 3 digit security code is stored in the EEPROM and will remain there even if power is removed. Make sure that the security code you assign is different for each of the positioner’s in the area.

Resetting the EEPROM Back to Factory Default Values

The positioner has an internal Electrically Erasable Programmable Read Only Memory (EEPROM) that is used to store the calibration values and the IR Remote security code. These values remain in the EEPROM memory even if power is removed from the positioner. During normal operation of the positioner the EEPROM will not have to be reset. The memory may become corrupted if power to the positioner is lost while the positioner is writing to the EEPROM. which only happens at the very end of the calibration cycle or at the end of the Position Sensor Initial Angle setup. This memory can be reset back to factory default values by holding down the HIgh Cal button while the positioner is being powered up. After the EEPROM is reset, the positioner will have to be calibrated again and the IR Remote security code will have to be set again.

Reversing the 4mA and 20mA Positions (Reverse Acting)

Normally 4mA of input current represents the closed valve position and 20mA represents the open valve position. The positioner has the option to switch this so 20mA represents the closed valve position and 4mA represents the open valve position. The normal mode is chosen by setting the positioner DIP Switch position 1 (the one closest to the LED’s) to the “OFF” position (toward the LED’s). The reverse acting mode is chosen by setting the positioner DIP switch position 1 to the “ON” position (away from the LED’s). The positioner should be calibrated again any time the switch position is changed.

Setting the Switches

1. Operate the actuator to one extreme. Choose the switch you would like to signal this position (upper or lower switch). Disengage the appropriate switch cam from the spline by pushing or pulling against the spring (push down for the upper switch, lift up for the lower switch).
2. Turn the cam until the switch is activated. Activation of the switch can be monitored using a continuity tester or equivalent means.
3. Release the cam allowing it to re-engage with the spline.
4. Operate the actuator to the opposite extreme and repeat steps 1 through 3 for the other switch.

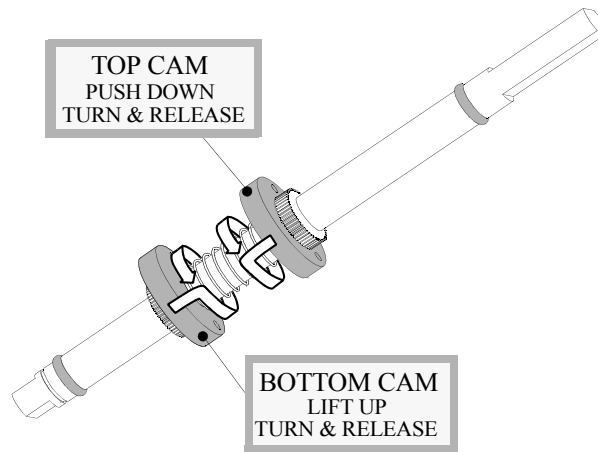

Wiring Schematic

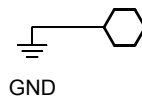
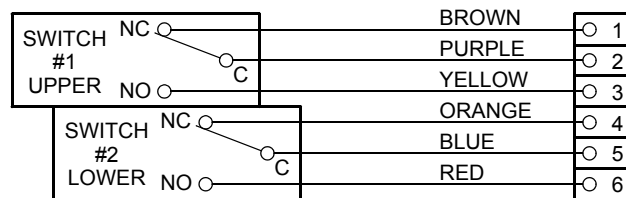

Parts List

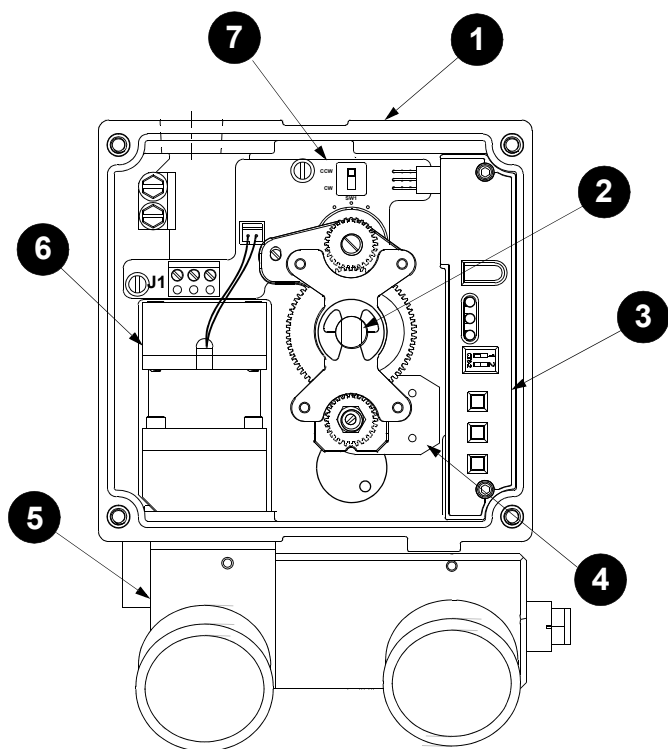

K10 Parts Description		
Item #	Qty	Description
1	1	Housing Ass'y
2	1	Shaft Ass'y
3	1	Electronic Ass'y
4	1	Transmitter (optional)
5	1	Manifold Ass'y
6	1	Motor Ass'y
7	1	Connector Board Ass'y
8	1	Mechanical Switch Ass'y (optional)

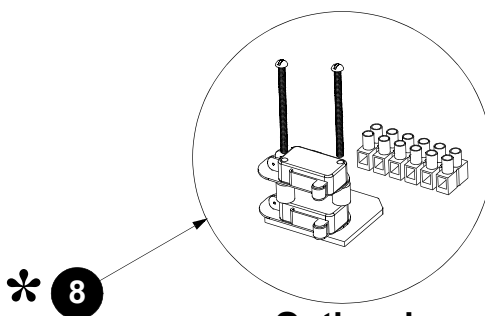

**Optional
Mechanical Switch
Assembly**

*** Void FM approval as Non-Incendive when ordered with 2-SPDT switch option .
K10 product with optional switches is for use in general purpose applications only.**

Technical Data

Operating Specifications	
Input Current	4 to 20 mA (Analog)
Voltage Drop	9 volts
Supply Air Pressure	(low) 15 to 45 psi (high) 40 to 120 psi
Resolution	0.5% of span
Linearity	±1% of span
Hysteresis	0.4% of span
Repeatability	0.4% of span
Thermal Coefficient	3%/100°C
Output Flow Rates	8.0 scfm @ 25 psi 16.2 scfm @ 90 psi
Air Consumption	.30 scfm @ 25 psi .71 scfm @ 90 psi
Operating Temp. Range	-40°C to 85°C (-40°F to 185°F)
Gain	Electrically Adjustable
Air Connection Ports	1/4" NPT

Materials of Construction	
Housing	Engineered Resin (Nylon)
Cover	Clear Engineered Resin (Nylon)
Shaft	Stainless Steel
Fasteners	Stainless Steel
HiVue	Copolyester
Manifold	Anodized Aluminum
ModMount	Engineered Resin (Nylon)

*

V3 Mechanical Switches	
Electrical Version	SPDT form C
Electrical Rating	15 Amps @ 125/250 VAC 10 Amps @ 24 VDC 0.5 Amps @ 125 VDC 0.25 Amps @ 250 VDC

Area Classification & Approvals	
	<p>* Non-Incendive Class I, Div 2 Grps A,B,C,D Class II, Div 2 Grps F,G Class III, Div 2</p>

Enclosure	
Conduit Entries	1 x 3/4" NPT

* Void FM approval as Non-Incendive when ordered with 2-SPDT switch option .
K10 product with optional switches is for use in general purpose applications only.

Dimensions

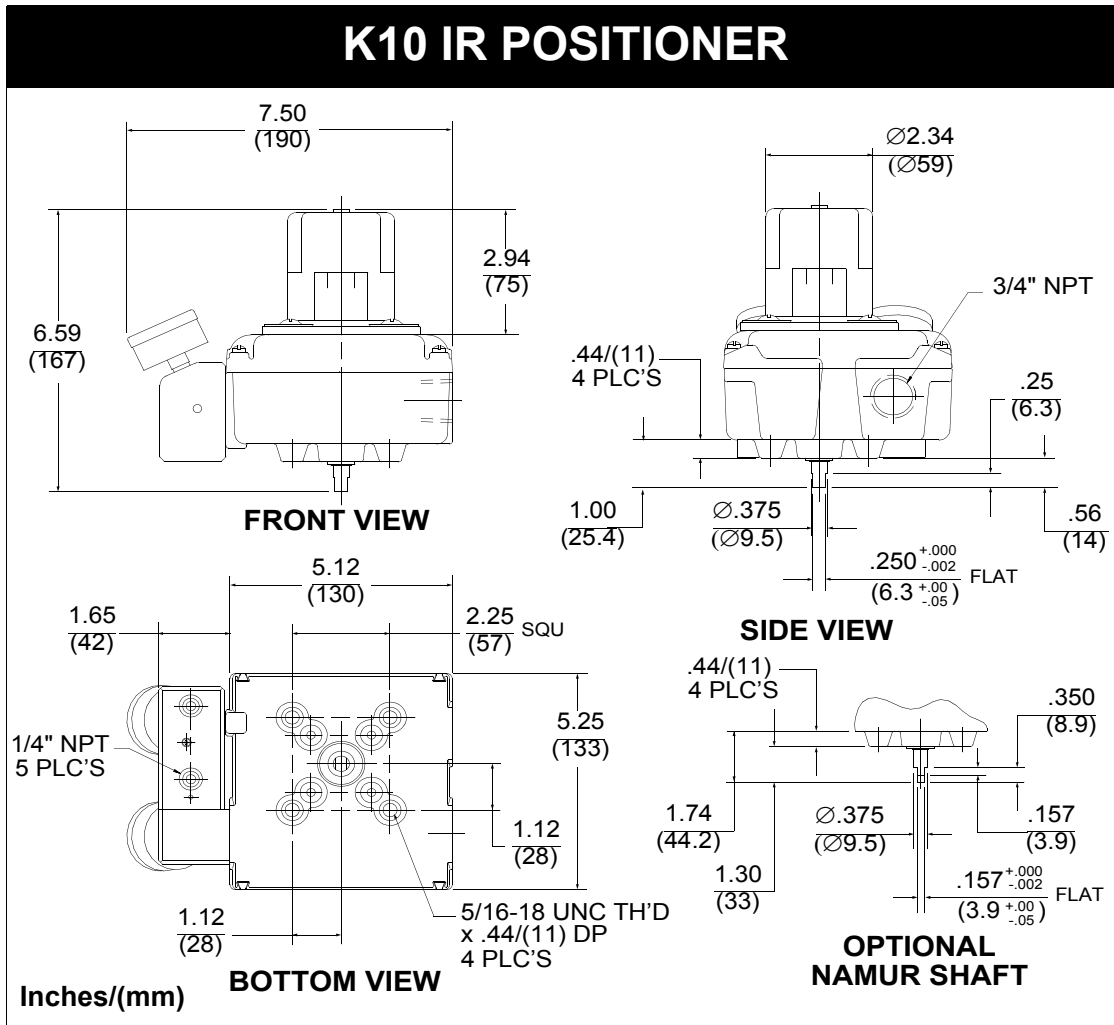

Appendix A

Electro-Pneumatic Positioner Transmitter Calibration Procedure

1. Calibrate the Positioner per the operating manual provided with the product.
2. Stroke the valve to the fully clockwise extreme.
3. Depress the main shaft gear disengaging it from its locking position, take extreme care Not to Turn the main shaft gear, as this will take the positioner out of calibration.
4. With the main shaft gear depressed turn the transmitter gear to the fully counter clockwise position, and note the reading (mA) of the transmitter. Next, turn the transmitter gear clockwise until the transmitter changes no more then 0.5 mA from previous reading.
5. Turn the clockwise mA adjustment screw to adjust the transmitter reading to the desired output for this valve position (typically this is 4 mA or 20 mA).
6. Stroke the valve to the fully counter clockwise extreme.
7. Turn the counter clockwise mA adjustment screw to adjust the transmitter reading to the desired output for this valve position.
8. Stroke the valve between the full clockwise and counter-clockwise positions checking and readjusting the (mA) output as necessary.

