

# Pneumatic Actuators

## Troubleshooting

### What if valve does not cycle?

1. No power source to solenoid. Check for power.
2. Power source disconnected. Check for broken wire or loose connection.
3. Low or wrong power source. Check for proper voltage.
4. Air not supplied to solenoid valve. Check air supply.
5. Air supply set too low. Adjust air pressure.
6. Speed control on solenoid valve set incorrectly. Adjust.
7. Filter regulator clogged or dirty. Inspect and clean.
8. Lubricant in air supply not compatible with O-ring material. Consult factory for chemical resistance.
9. Manual override engaged on solenoid. Dis-engage.

### What if the valve does not fully open or close?

1. Air supply set too low. Adjust pressure.
2. Speed control on solenoid valve set incorrectly. Adjust.
3. Foreign material is caught in valve limiting travel. Inspect valve and replace parts as needed as per the appropriate IOM.
4. Actuator not properly sized for an air supply of less than 80-psi.
5. Filter regulator clogged or dirty. Inspect and clean.
6. Camstop adjusted to limit travel. Check adjustment.

### What if air leaks out of solenoid?

1. Supply line not properly tightened into solenoid valve body. Check tightness.
2. Solenoid body damaged from over tightening. Inspect and replace if required.
3. Solenoid valve not properly tightened to actuator housing (NAMUR style).
4. Solenoid gasket not properly seated against actuator body. Inspect gasket and replace or reposition.
5. Piston O-rings worn. Rebuild actuator with appropriate repair kit per appropriate IOM.

## Options

### Filter/Regulator

The filter/regulator filters the supply air to 20 microns while regulating the air supply from 0-125 psig. The filter/regulator has a powder coated zinc body with 1/4" FNPT connection ports, is piston operated and self-relieving. The bowl is 1.5 ounces and features a manual drain port for cleaning.

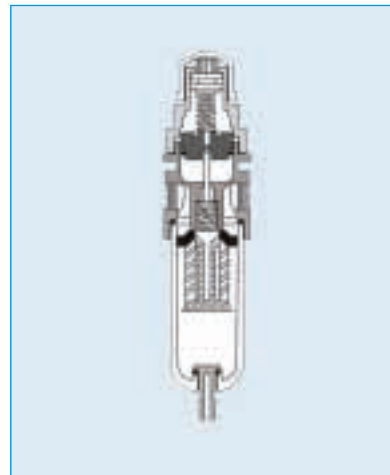

### Mechanical Travel Stop

A mechanical travel stop (camstop) is available for the Series 79 pneumatic actuators. The camstop allows for independent adjustment of the opening stroke, closing stroke or both simultaneously. It is mounted in between the actuator and the valve mounting kit, with the camstop acting as the actuator to valve coupling.

