

Ball Valve Stem Extensions and Options

Stem Extensions

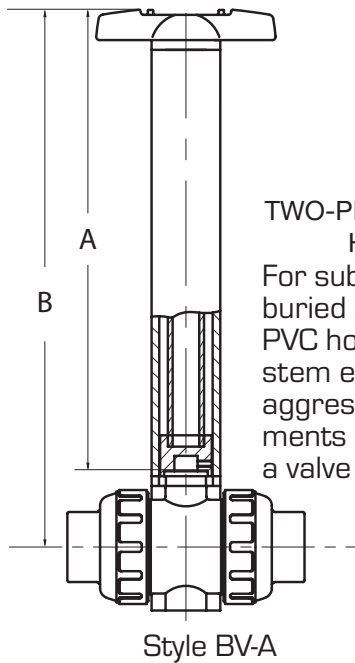

TWO-PIECE STEM AND HOUSING
For submerged or buried applications. PVC housing protects stem extensions from aggressive environments or functions as a valve box.

Style BV-A

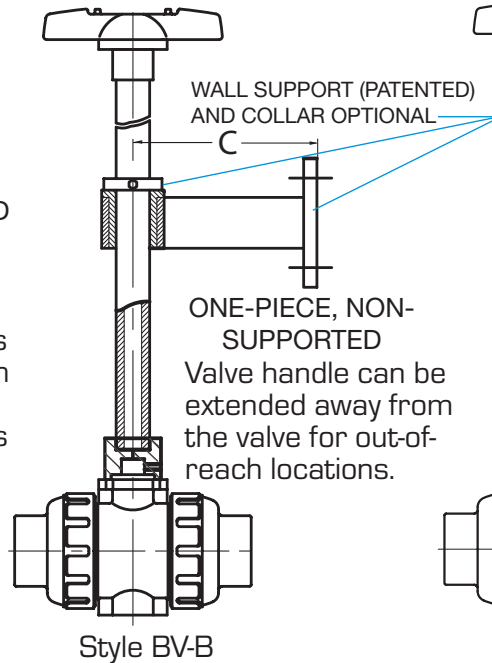

ONE-PIECE, NON-SUPPORTED
Valve handle can be extended away from the valve for out-of-reach locations.

Style BV-B

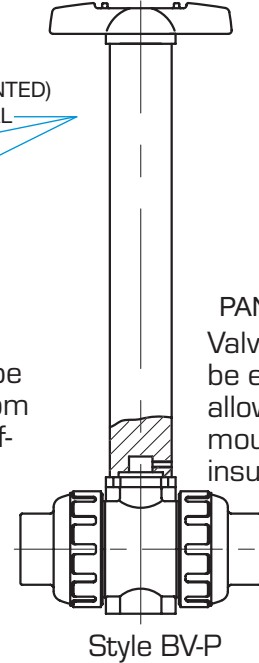

PANEL MOUNT
Valve handle can be extended to allow for panel mount and pipe insulation

Style BV-P

Locking Handles

THIS SPECIAL LOCKING UNIT CONSISTS OF A HANDLE COVER AND PADLOCK TO PREVENT UNAUTHORIZED CYCLING OF A VALVE.



Panel Mount

VALVE HANDLE IS EXTENDED FOR PANEL MOUNT (STYLE BV-P) APPLICATION. PLEASE SPECIFY LENGTH OF EXTENSION 4" MIN. LENGTH 12" MAX. LENGTH.



Remote Operating Nuts

2" SQUARE OPERATING NUTS OR "T" OPERATING NUTS MAY BE INSTALLED ON ANY BALL VALVE. THEY ARE USED FOR REMOTE OPERATION OF A VALVE WITH AN EXTENDED WRENCH.



Limit Switches

MANUAL BALL VALVES ARE AVAILABLE WITH LIMIT SWITCHES (SPDT) FOR SEQUENCING WITH OTHER EQUIPMENT OR FOR REMOTE POSITION INDICATION WITH LIGHTS.

